

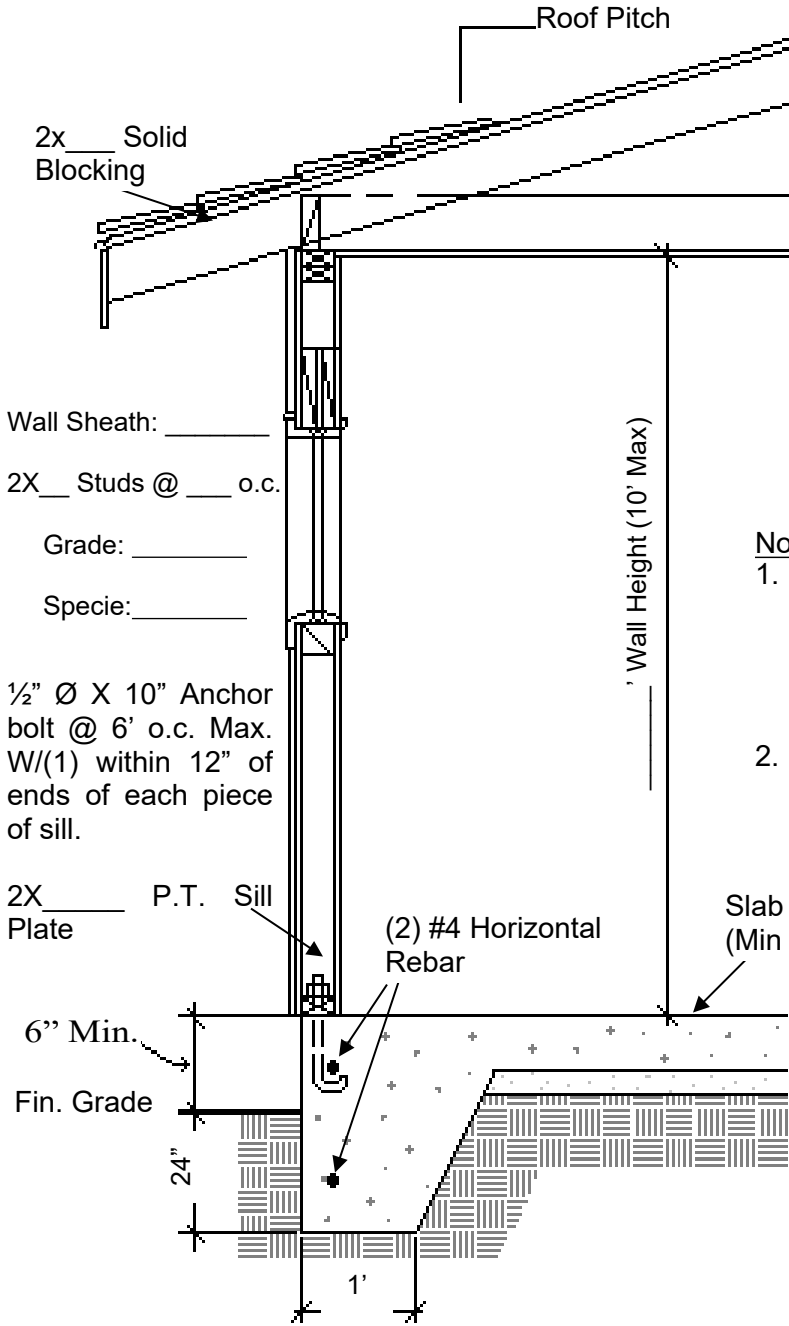

WOOD FRAME ACCESSORY STRUCTURE



**WALL SECTION – MONOLITHIC SLAB
 UNHEATED**

Roofing: _____
 Sheathing: _____

Roof Framing:

If using manufactured trusses, provide a copy of the truss sheet from the truss manufacturer or specify:

2X _____ Rafters @ _____" o.c.
 Specie: _____, Grade: _____
 2X _____ Ceiling Joists @ _____" o.c.
 Specie: _____, Grade: _____

Notes:

1. If interior is finished,
 - a. Specify finish material
 - b. Provide Min. 22" X 30" attic access if any portion of attic is greater than 30" in height.
 - c. Specify how attic ventilation will be provided.
2. If lot is not flat,
 - a. Provide elevations showing finished grade.

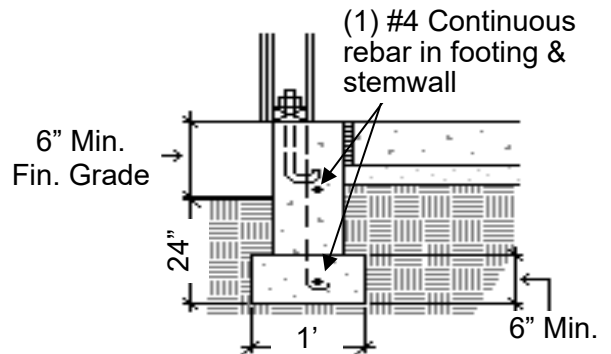

**STEMWALL FOOTING
 UNHEATED**

FLOOR PLAN

